



# AP2500

SUBMERSIBLE UTILITY PUMP

OPERATIONS MANUAL

[WWW.ECOAQUAPRO.COM](http://WWW.ECOAQUAPRO.COM)

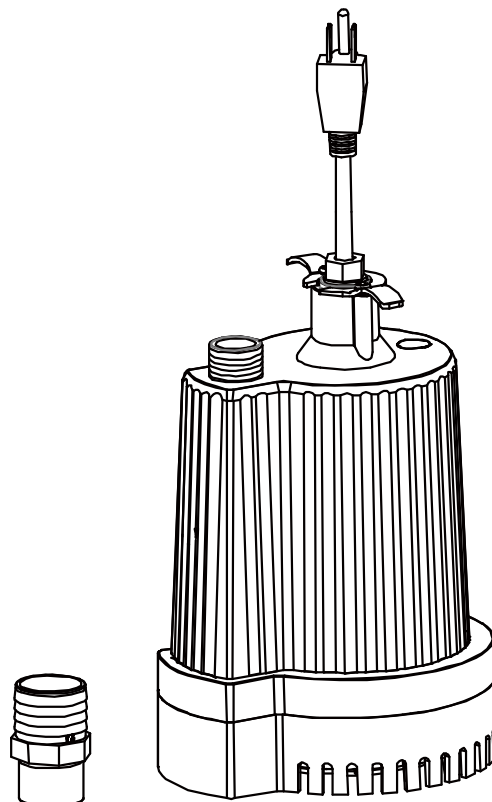

## Performance

Model	HP	GPH of Water @ Total Feet Of Lift						Max. Lift
		0 ft.	5 ft.	10 ft.	15 ft.	20 ft.	25 ft.	
AP2500	1/6	1500	1400	1300	1100	750	300	26 ft.

## Safety Information

Please read and understand this entire manual before attempting to assemble, operate or install the product. If you have any questions regarding the product, please call customer service at 877-278-2797

### DANGER

1. Do not touch the motor housing during operation. The motor is designed to operate at high temperatures. Do not disassemble the motor housing.
2. Do not pump flammable or explosive liquids such as oil, gasoline, kerosene, ethanol, etc. Do not use in the presence of flammable or explosive vapors. Using this pump with or near flammable liquids can cause an explosion or fire, resulting in property damage, serious personal injury and/or death.
3. ALWAYS disconnect the power to the pump before servicing.
4. Do not handle pump or pump motor with wet hands or when standing on wet or damp surface, or in water.

### WARNING

1. Release all pressure and drain all water from system before servicing any component.
2. Secure discharge line before starting the pump. An unsecured discharge line will whip, possibly causing personal injury and/or property damage.
3. Extension cords may not deliver sufficient voltage to the pump motor. Extension cords present a life threatening safety hazard if the insulation becomes damaged or the connection ends fall into water. The use of an extension cord to power this pump is not permitted.
4. Wear safety goggles at all times when working with pumps.
5. This unit is designed only for use on 115 volts (single phase), 60 Hz, and is equipped with an approved 3-conductor cord and 3-prong grounded plug. **DO NOT REMOVE THE GROUND PIN UNDER ANY CIRCUMSTANCES.** The 3-prong plug must be directly inserted into a properly installed and grounded 3-prong, grounding-type receptacle. Do not use this pump with a 2-prong wall outlet. Replace the 2-prong outlet with a properly grounded 3-prong receptacle (a GFCI outlet) installed in accordance with the National Electrical Code and local codes and ordinances. All wiring should be performed by a qualified electrician.
6. Protect the electrical cord from sharp objects, hot surfaces, oil, and chemicals. Avoid kinking the cord. Do not use damaged or worn cords.
7. Failure to comply with instruction and designed operation of this unit, may void warranty. **ATTEMPTING TO USE A DAMAGED PUMP can result property damage, serious personal injury and/or death.**
8. Make certain the electrical circuit to the pump is protected by a 10 Amp fuse or circuit breaker.

### CAUTION

1. Do not lift pump by the power cord.
2. Know the pump and its applications, limitations, and potential hazards.
3. Secure the pump to a solid base. This will aid in keeping the pump in a vertical orientation. This is critical in keeping the pump operating at maximum efficiency. It will also help prevent the pump from clogging resulting in premature failure.

4. Periodically inspect the pump and system components to be sure the pump inlets are free of mud, sand, and debris. DISCONNECT THE PUMP FROM THE POWER SUPPLY BEFORE INSPECTING.
5. Follow all local electrical and safety codes, along with the National Electrical Code (NEC) . In additional, all Occupational Safety and Health Administration (OSHA) guidelines must be followed.



## IMPORTANT

1. The motor of this pump has a thermal protector that will trip if the motor becomes too hot. The protector will reset itself once the motor cools down and an acceptable temperature has been reached. The pump may start unexpectedly if it is plugged in.
2. Make certain the electrical power source is adequate for the requirements of the pump.
3. Before using the pump, check hose for holes or excess wear, which could cause leaks, and be sure hose is not kinked or making sharp angles. A straight hose allows the pump to move the greatest amount of water quickly, and also check that all hose connections are tight to minimize leaks.



## NOTE

1. This pump is made of high-strength, corrosion-resistant materials. It will provide trouble-free service for a long time when properly installed, maintained, and used. However, inadequate electrical power to the pump, dirt, or debris may cause the pump to fail. Please carefully read the manual and follow the instructions regarding common pump problems and remedies.
2. Always make sure the pump is unplugged as soon as the water level reaches 1/2 in. At water levels less than 1/2 in., the pump is attempting to pump air, which will cause the pump to overheat and wear out. Running the pump without sufficient water will damage the pump and void the pump's warranty

## Application

The submersible pump is designed for water removal applications. Use this pump only for pumping water. It can drain or remove water from the following: pits, sinks, window wells, basements, swimming pool covers, boats, low spots in yards, or other flooded areas.

This pump is not designed to function as a permanently installed sump pump. It is also not engineered to be run continuously as a "fountain" or "waterfall" pump.

### Features:

- Ending water level – max-----1/2"
- Operating water depth - beginning minimum -----1"

## Pre-installation

### TOOLS REQUIRED

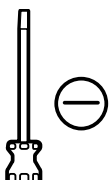

Flathead  
Screwdriver

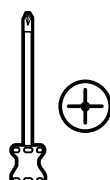

Phillips  
Screwdriver



Safety goggles

## MATERIALS REQUIRED (NOT INCLUDED)

 **NOTE:** Hose and hose kit shown not to scale

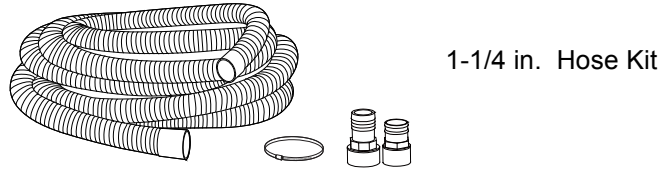
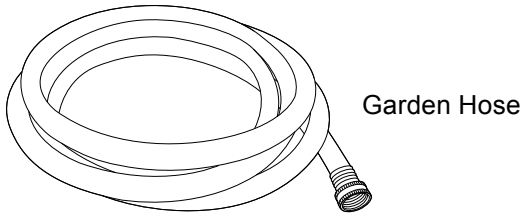

## PACKAGE CONTENTS

 **NOTE:** Adapter shown not to scale

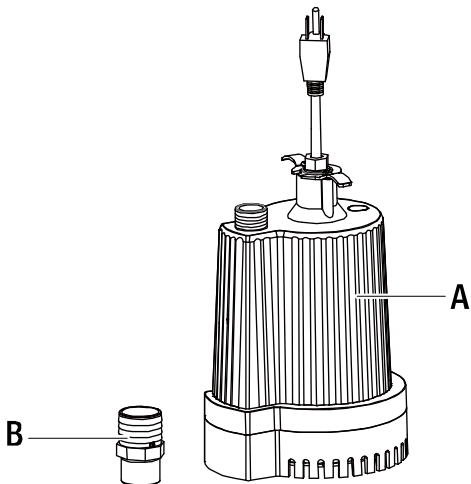

Part	Description
A	Pump
B	1-1/4in. hose adapter

## Pre-installation(continued)

### ESTIMATED INSTALLATION TIME

5 minutes

### SPECIFICATIONS

Voltage	115V (single phase)
Hertz	60Hz
Ampere	10A (GFCI 3-prong receptacle)

# Installation



**CAUTION:** Always use the handle to lift the pump. Never use the power cord to lift the pump. To avoid skin burns, unplug the pump and allow time for it to cool after periods of extended use.

## 5/8 in. Garden Hose Connection

Attach a 5/8 in. inside diameter or larger garden hose (not included) to the pump outlet.



**NOTE:** Be sure the hose end has a rubber washer to minimize water leaks.

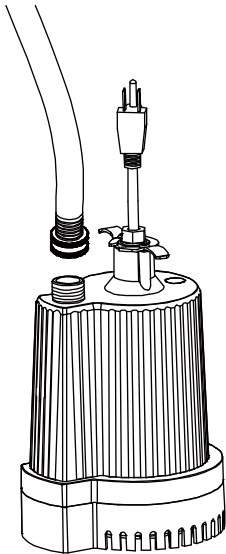

## 1-1/4 in. Hose Kit Connection

If you would prefer to use a larger hose in order to pump water away more quickly, attach the included adaptor to pump, and then securely attach the Hose Kit (sold separately) to the adaptor.



**WARNING:** Secure the discharge hose before plugging in the pump. Pump torque may cause an unsecured discharge hose to “whip”, possibly causing personal injury and/or property damage.

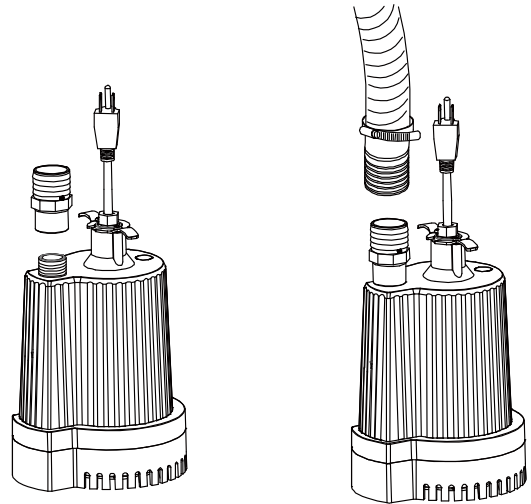

# Operation

**1** Place the pump in flooded area or any place that you would like to remove water. And plug the pump into a 115 volt GFCI power outlet.

**2** Allow pump to run and monitor its progress. UNPLUG when pump has removed water down to approximately 1/2 “. Remove the pump and hose from the location when finished pumping, as the hose still has water that can drain back through the pump. Remove remaining



**NOTE:** After starting, the pump will lower the water level to 1/2” (12.7mm) before losing suction. It will not pick up water less than 1/2” (12.7mm) deep when running and will not operate successfully if started in

only 1/2" (12.7mm) of water.



**NOTE:** The pump must be standing in at least 1" (25.4mm) of water before starting it. The shaft seal is water lubricated and may be damaged if pump runs dry.



**NOTE:** Place upright on a solid base.



**WARNING:** Do not handle pump or pump motor with wet hands or when standing on wet or damp surface, or in water.

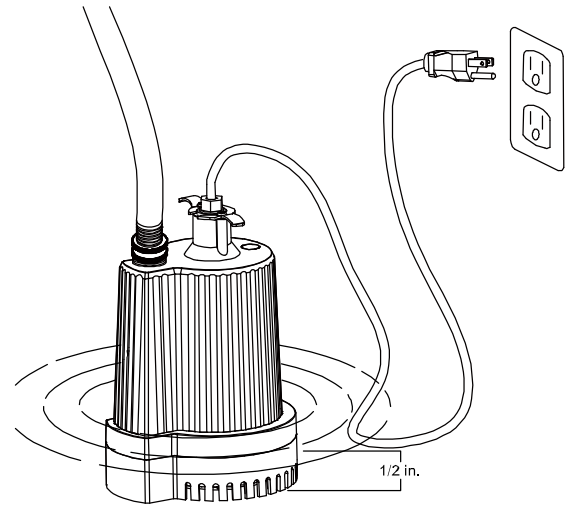

**CAUTION:** Do not run the pump dry. Operating the pump without water will cause damage to seals and will cause the pump to fail, thereby voiding the pump's warranty.

## Airlock

This pump is a centrifugal utility pump, designed to efficiently remove water. However, it cannot move air. If air is trapped inside the pump (a condition called "airlock"), the pump cannot pump water out even though the pump is completely submerged. This pump has an anti-airlock hole. Air flows out through the anti-airlock hole, eliminating the air so that the pump can operate properly. If debris blocks the anti-airlock hole or if the anti-airlock hole cannot move freely, unplug the pump, clean out the anti-airlock hole, and restart the pump. Alternately, drain the water out of the garden hose, keep the end of the hose out of the water, and plug in the power cord, restarting the pump.



**CAUTION:** This hole is for anti-airlock purpose, leakage of air or water is NORMAL and NECESSARY. DO NOT REMOVE OR PLUG THIS HOLE!

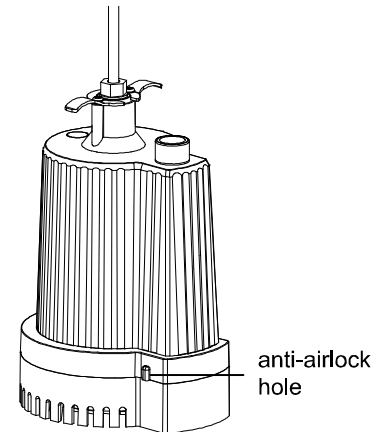

## Care and Cleaning



**CAUTION:** Always use the handle to lift the pump. Never use the power cord to lift the pump. To avoid skin burns, unplug the pump and allow time for it to cool after periods of extended use.

### Do

- When the power is disconnected, inspect the pump inlets and remove all debris, then plug pump back into the grounded (GFCI) outlet

### Do Not

- Disassemble the motor housing. This motor has NO repairable internal parts, and disassembly may cause leakage or dangerous electrical wiring issues.
- Lift up the pump by the power cord.

To clear a pump clogged with debris, first, UNPLUG PUMP from electrical power. Then, referring to the following picture, unscrew the stainless screws (5), and remove the volute (4), use a flathead screwdriver to hold the shaft (1), then turn the impeller (2) counterclockwise to release the impeller (2). Remove debris from around the shaft (1) and on/under the impeller (2). Reassemble.

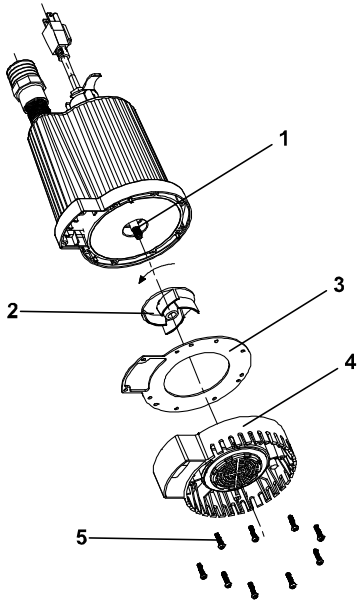

Item	Description	Quantity
1	Shaft	1
2	Impeller	1
3	Gasket	1
4	Volute	1
5	Screw	9

## Troubleshooting

Problem	Possible Cause	Corrective Action
Pump does not start or run	<ol style="list-style-type: none"> <li>1. Blown fuse</li> <li>2. Tripped breaker</li> <li>3. Plug disconnected</li> <li>4. Thermal overload</li> <li>5. Corroded plug</li> <li>6. Motor failed</li> </ol>	<ol style="list-style-type: none"> <li>1. Replace fuse</li> <li>2. Reset breaker</li> <li>3. Secure plug</li> <li>4. Unplug the pump for 30 minutes, then plug in</li> <li>5. Clean plug prongs</li> <li>6. Call 877-278-2797</li> </ol>
Pump cannot pump water out	<ol style="list-style-type: none"> <li>1. Screen blocked</li> <li>2. Hose kinked, bent sharply, or coiled</li> <li>3. Airlock</li> <li>4. Impeller loose on shaft</li> <li>5. Impeller broken</li> </ol>	<ol style="list-style-type: none"> <li>1. Clean screen</li> <li>2. Straighten hose</li> <li>3. Clean anti- airlock hole</li> <li>4. Reassemble impeller</li> <li>5. Call 877-278-2797</li> </ol>

# Warranty

## ***Limited Warranty***

For one (1) year from the date of purchase, AquaPro will repair or replace, at its option, for the original owner any parts of its filters ("Product") which are found upon examination to be defective in materials or workmanship. This Limited Warranty covers parts only for a period of one (1) year.

Please call 1-877-278-2797 for instructions. Be prepared to provide a receipt, the model number and serial number when exercising this limited warranty.

Purchaser must pay all transportation charges on Products or parts submitted for repair or replacement.

All non-warranty service charges are the responsibility of the original owner. Failure to pay for non-warranty service charges will void this Limited Warranty.

This Limited Warranty does not cover Products that have been damaged as a result of accident, freezing, abuse, misuse, neglect, improper installation, improper maintenance or failure to operate in accordance with written instructions. All maintenance and service must be performed by service agents approved. Any unauthorized alteration or repairs will void this Limited Warranty.

**THERE IS NO OTHER EXPRESS WARRANTY. IMPLIED WARRANTIES, INCLUDING THOSE OF MERCHANTABILITY AND FITNESS FOR A PARTICULAR PURPOSE, ARE LIMITED TO ONE (1) YEAR FROM THE DATE OF PURCHASE. THIS IS THE EXCLUSIVE REMEDY AND ANY LIABILITY FOR ANY AND ALL INDIRECT OR CONSEQUENTIAL DAMAGES OR EXPENSES WHATSOEVER IS EXCLUDED.**

Some states do not allow limitations on how long an implied warranty lasts, or do not allow the exclusions or limitations of incidental or consequential damages, so the above limitations might not apply to you. This limited warranty gives you specific legal rights, and you may also have other legal rights which vary from state to state.

In no event, whether as a result of breach of contract warranty, tort (including negligence) or otherwise, shall its suppliers be liable for any special, consequential, incidental or penal damages including, but not limited to loss of profit or revenues, loss of use of the products or any associated equipment, damage to associated equipment, cost of capital, cost of substitute products, facilities, services or replacement power, downtime costs, or claims of buyer's customers for such damages.

This Limited Warranty does not include freight charges for equipment or component parts, to and from the factory, services such as maintenance or inspection, repair or damage due to negligence such as freezing conditions, incorrect installation, nor acts of God. The liability shall not exceed the repair or replacement of defective parts under this Limited Warranty. This Limited Warranty also does not include unnecessary service calls due to erroneous operational reports, external valve positions, or electrical service. If a non-warranty service call is made, and the homeowner is unwilling to pay for the service call, this Limited Warranty will be voided. This Limited Warranty is voided if the product is repaired or altered by any persons or agencies other than those authorized. This Limited warranty applies only within the continental USA.

You **MUST** retain your purchase receipt along with this form. In the event you need to exercise a warranty claim, you **MUST** present a **copy** of the purchase receipt at the time of service. Please call 1-877-278-2797 for service or return authorization and instructions.

**DO NOT MAIL THIS FORM.** Use this form only to maintain your records



MODEL NO. \_\_\_\_\_ SERIAL NO. \_\_\_\_\_ INSTALLATION DATE \_\_\_\_\_